

MX-520 Sample Work
Part for Semiconductor Industry



Key Points!

- ***Process integration by 3+2 machining!***
(9 processes → 2 processes)
- ***Drastic reduction in work setup time!***
- ***Superb machining accuracy!***

● **Photos**

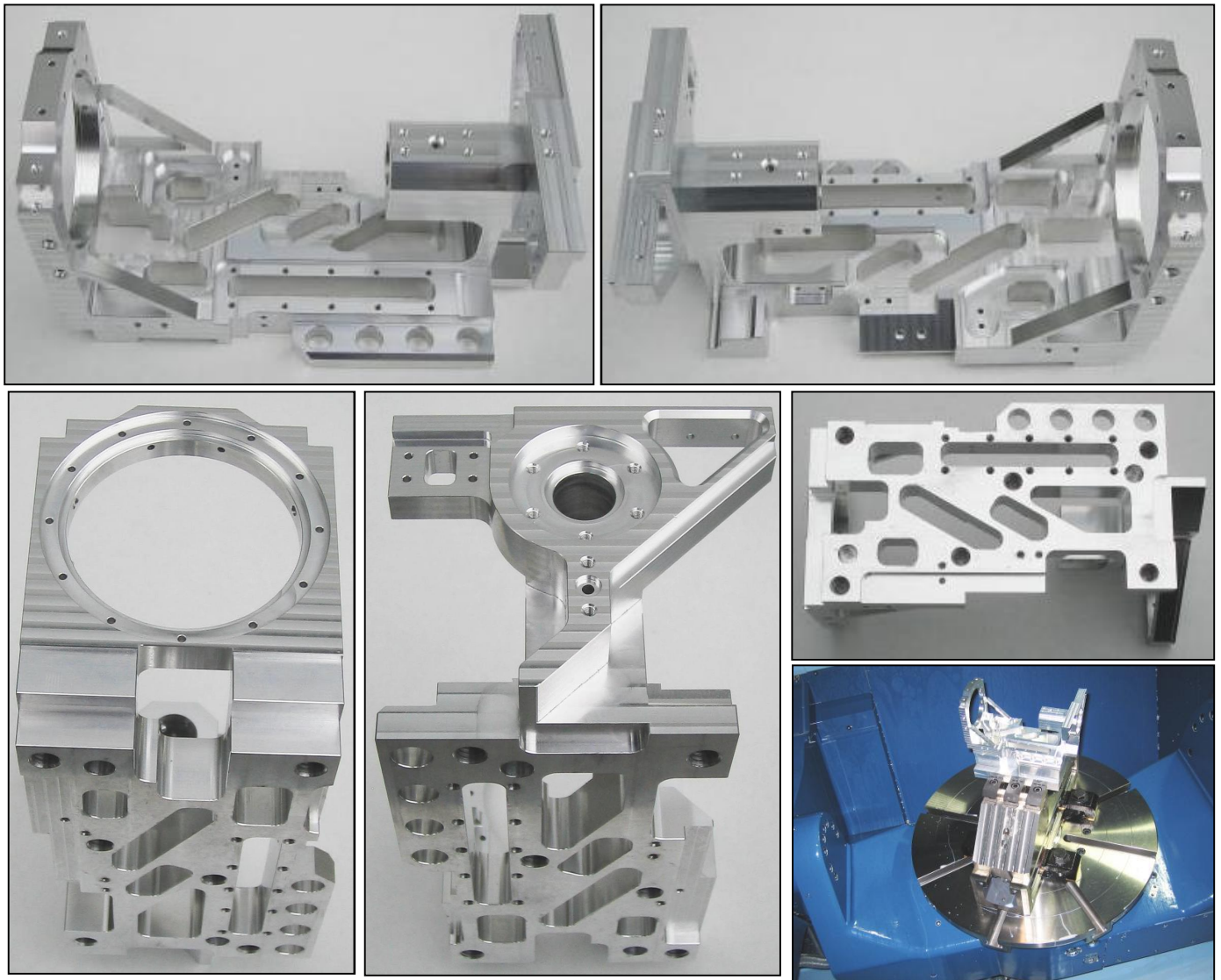

MX-520 Sample Work
Part for Semiconductor Industry



● **Machining Accuracy**

			Machining Accuracy	
			Target	Result
①	Squareness	⊥	0.010	0.0053
②	Coaxiality	◎	0.010	0.0083
③	Parallelism	//	0.010	0.0070

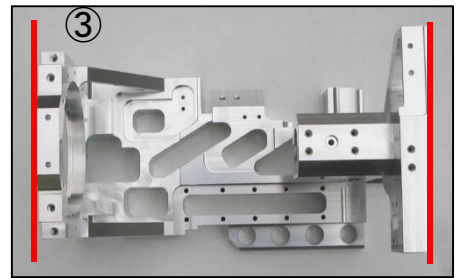
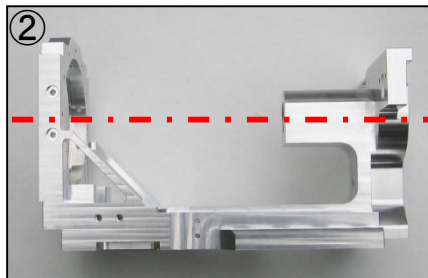
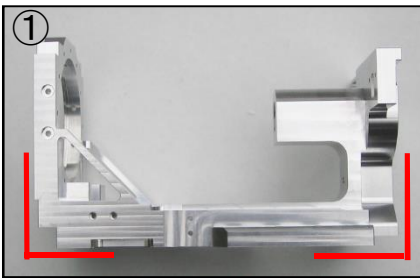

Above is only the measured value and not guaranteed value.

● **MX-520 Spec.**

Spindle	12,000min ⁻¹
ATC	60 Tools
Feedrate	XYZ 40m/min

